



GX2140-DLBO
GSM SMS BATTERY OPERATED ALARM UNIT

USER MANUAL

GX2140-DLBO-rev1.01-1121

SAFETY INSTRUCTIONS

- This user manual contains important notices for installation, usage and safety instructions. Please read this manual carefully before you start using your device!
- Device is containing a radio transceiver operating on GSM 850/900/1800/1900 MHz bands.
- Do not use device in environments, exceeding temperature limits (device should operate not lower than -10⁰ C and not higher than +50⁰ C).
- Do not use device in chemical or other hazardous environments.
- Device is intended to use in dry and clean places. Do not use device in high humidity.
- Protect your device from dust, moisture, heat and water.
- Do not expose the device to strong vibrations and mechanical impacts.
- Do not attempt to repair device personally.

USE IN ACCORDANCE WITH THE REGULATION

- The use of this device in accordance with the regulation is sending SMS text messages and making phone calls after an alarm case and controlling remote devices via SMS and phone calls. Other usages are not permitted.
- Police, fire or healthcare emergency call lines are not permitted to call directly from this device. Do not configure emergency call numbers into this device.

BATTERY RECYCLING

- CR123A Lithium batteries are classified as recycled batteries. Please take your empty batteries to a nearest collection point.

BATTERY LIFE

- Battery life, announced by manufacturer, is calculated under normal operating conditions and normal frequency of usage.
- Battery life can vary against frequency of usage, quality of cellular service, environment conditions (temperature, humidity etc.), quality of used batteries and other effects.
- Manufacturer does not guarantee battery life of the device operation.

LIMITED LIABILITY

- The buyer must agree that Reporter devices will reduce the risk of theft, burglary, fire or other dangers and controls remote devices but do not guarantee any operation against such events.
- Manufacturer will not take any responsibility regarding personal or property or revenue loss while using devices.
- Manufacturer liability according to local laws does not exceed value of the purchased device.

1. DESCRIPTION

Reporter GX2140 is a user friendly and a reliable device which sends you SMS text messages and calls you in case of input alarm events, restorations and periodically sends heartbeat messages. It is completely battery operated with more than 1 year battery life.

It includes a lot of useful features like; configurable SMS text messages, user defined heartbeat periods, alarm call enable/disable, add/delete phone numbers via SMS, LED indicators, replaceable antenna, IP67 water & dust protected industrial enclosure.

Please note; GX2140 stays in **low-power sleep mode** to save battery life, and it keeps detached from GSM network during sleep times. So, when you try to send SMS or Call the device; you will not be able to reach it. To make configurations; you will need to physically press the Config button inside the device, then you will be able to send configuration SMS texts to the device (Config mode).

Device wakes up only under below conditions:

- An input alert trigger
- A heartbeat period timeout
- Pressing Config button physically

GX2140-DLBO has:

- 4 x Volt-free inputs (non-isolated – self-powered)
- 3 admin nr capacity

Below list shows the alert events from your device:

- **Port1 High** : Text Message and (optional) phone call ring
- **Port1 Low** : Text Message and (optional) phone call ring
- **Port2 High** : Text Message and (optional) phone call ring
- **Port2 Low** : Text Message and (optional) phone call ring
- **Port3 High** : Text Message and (optional) phone call ring
- **Port3 Low** : Text Message and (optional) phone call ring
- **Port4 High** : Text Message and (optional) phone call ring
- **Port4 Low** : Text Message and (optional) phone call ring
- **Device Activated** : Detailed Text Message *
- **Keep Alive** : Detailed Text Message *
- **Status** : Detailed Text Message *

* Detailed text message includes: All inputs status, all outputs status, Call mode selection, Alarm call configuration, Keep alive period and CSQ GSM signal level.

Note that Reporter devices do not have “voice record” function, so phone calls are used for only ringing your mobile phone. There is no voice call.

Only a local 850/900/1800/1900 MHz GSM SIM card is required to operate the device. SMS and Call function is enough for SIM Card. Data or GPRS functions are not required.

All settings and registered admin & user numbers are saved in Reporter’s own memory. So, settings will not be deleted if power is failed, or SIM card is removed/replaced. Device will continue with the last saved settings & numbers.

2. USECASES

2.1. Input Monitoring

Any kind of volt-free sensor/switch/device output could be connected to Reporter inputs. Thus, Reporter will continuously check for any change on the inputs, and it will inform all Admins by SMS (optionally Free Phone Call) in case of changes on the inputs.

Use cases might be such as:

- Simple alarm system where is no external power
- Door/window monitoring
- Security call for public areas like parks, gardens
- Rattrap monitoring
- Letterbox monitoring
- Any sensors monitoring which have dry contact relay outputs (i.e. gas/smoke/earthquake)
- Caravans / yachts / boats / warehouses
- Water Flooding / Water Loss / Tank Level Alarms
- Transformer theft
- Panic button monitoring

3. INSTALLATION

Package includes:

- 4 x screws for “Cover Fitting”
- 4 x screws for “Wall Mount”
- 4 x fixing plugs for “Wall Mount”
- 1 x waterproofing fitting

Firstly, unscrew the Cover Fitting screws and then open the top cover.

If you want to mount your device to the wall;

- Place device to the wall
- Point Wall Mount screwing holes (shown below) to the wall
- Drill the wall from pointed places
- Insert fixing plugs into the drilled points
- Screw in the wall mount screws from the screwing points of the device

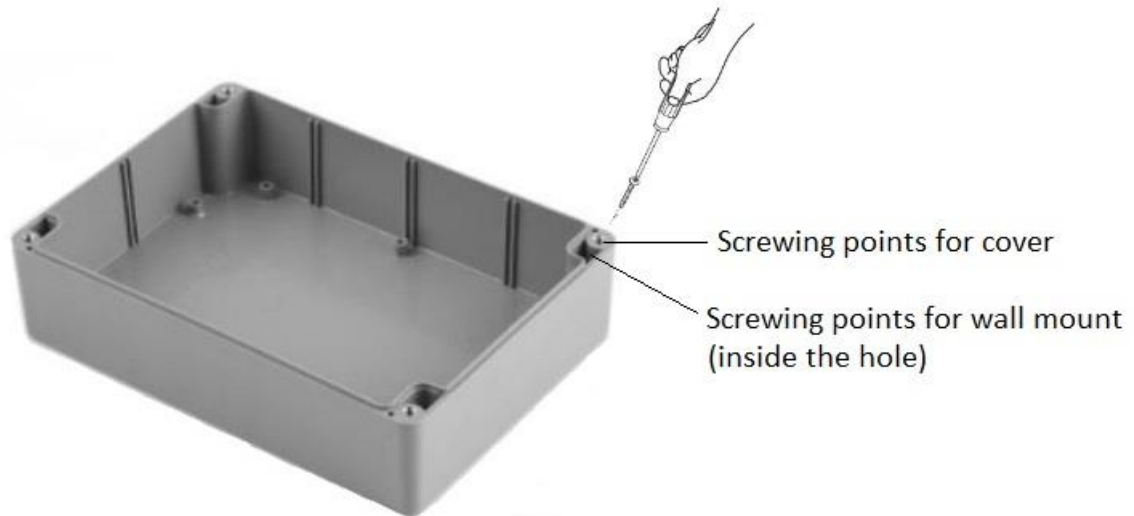

4. GETTING STARTED

4.1. Insert SIM Card

A local SIM card is required to operate the system.

Required SIM card size is NanoSIM (as seen in figure).

SMS and Call (if you require) services should be active on the SIM. However, Data/Internet/GPRS services are not required.

Before inserting the SIM card, try it with a mobile phone. And then:

- Disable PIN code protection
- Send an SMS to a mobile number for testing
- Call a mobile phone number for testing

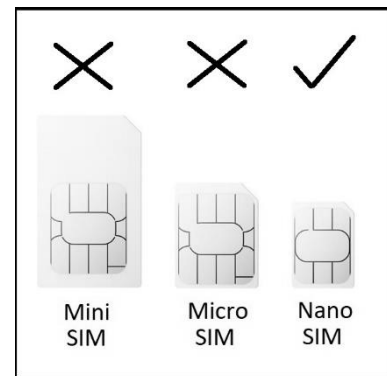

After above steps completed, open the screws. And insert SIM card into the device, by pushing it as shown in below figure.

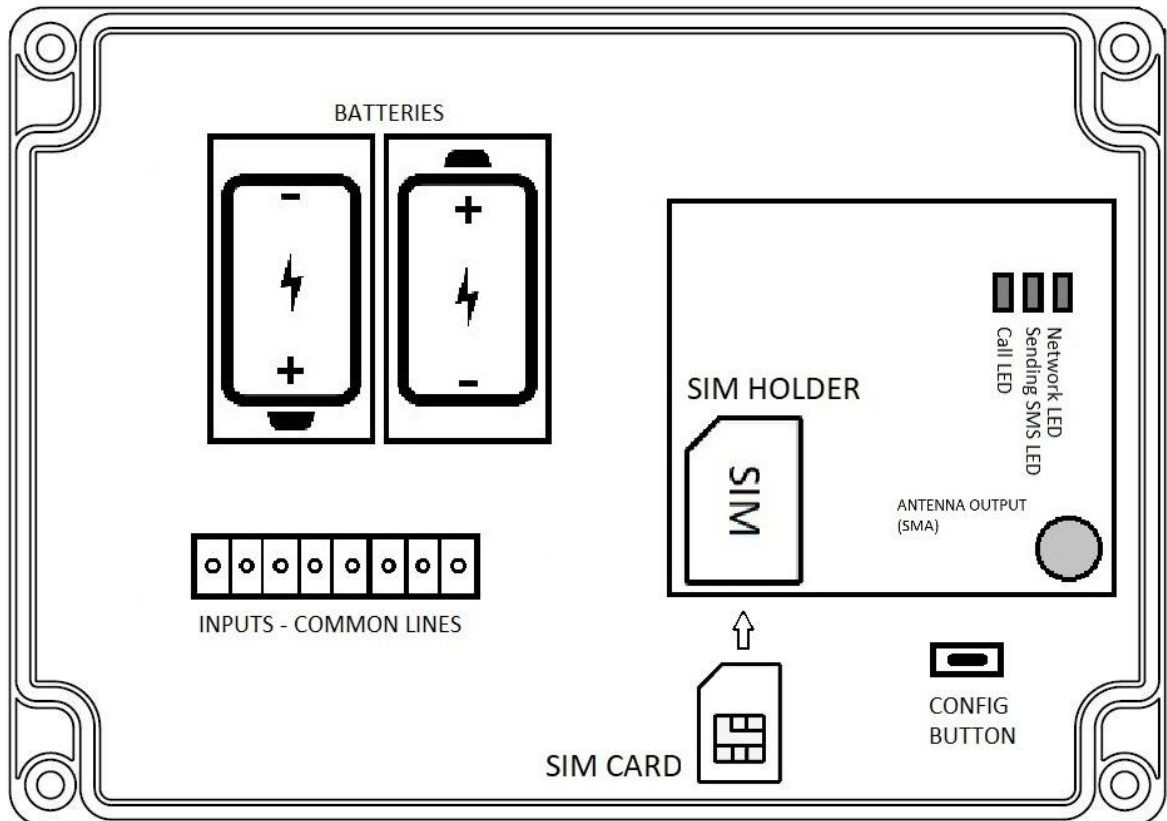

4.2. Connect Inputs on Ports

Note: Wires should pass into the holes of the bottom cover! Please check Wiring Diagram!

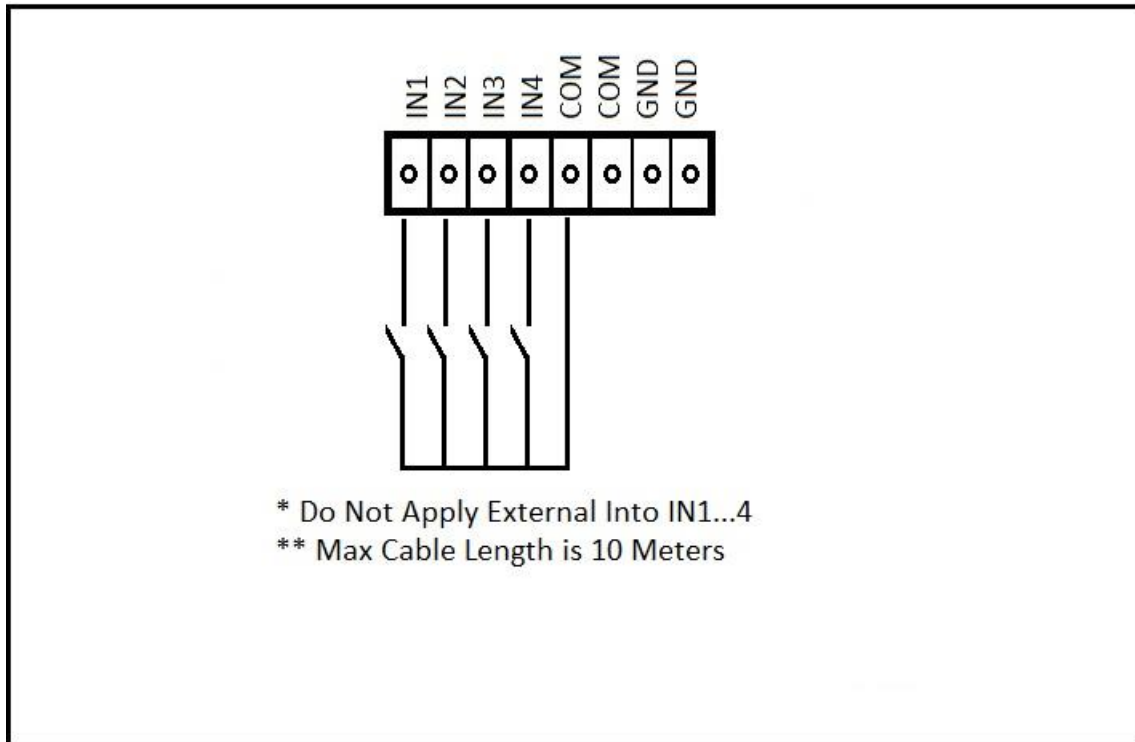

Only **volt-free** switches / sensors / relay outputs could be connected to GX2140 inputs.

It provides Positive Low Voltage from “COM” ports and checks the return from IN1...4 inputs.

4.3. Insert Batteries

Insert two pieces of CR123A or CR123 lithium batteries. Make sure you followed correct polarity of the batteries. You will see + / - indications on the board.

5. DEVICE CONFIGURATION

Firstly, make sure all LEDs are OFF.

Then press Config button for one second.

Then check for “NETWORK STATUS LED”.

- Off : Sleeping
- Fast Blink : Not ready (registering to network)
- Slow Blink : Ready (registered to the network)

Once NETWORK STATUS LED starts blinking slowly; then you are ready to go to next steps.

Note: Device will stay in Configuration for two minutes only. Make sure you make configurations during this period. When timeout is completed, and you couldn't finish configurations; try pressing the Config button again to restart two minutes timeout.

Note: Device Configuration and Reset is only made by SMS commands. There is no other method.

Below is the table of SMS commands available:

DESCRIPTION	COMMAND	DEFAULT	RANGE	AUTHORISATION
Change Password	PASS:xxxx	1111	0000..9999	ADMIN
Add Admin	ADDA:xxxxxxxxxx			ADMIN
Delete Admin	DELA:xxxxxxxxxx			ADMIN
Alert Calls Activate	CALL:ON	OFF		ADMIN
Alert Calls Deactivate	CALL:OFF	OFF		ADMIN
Change SMS Text Messages	PATx:yyyyyyyyy#		1..32 chars	ADMIN
Set Keep Alive (Heartbeat) SMS Period	KA:x	0 (means disabled)	0..999 hours	ADMIN
Get Device Status Info	STATUS			ADMIN
Restore Factory Settings	RESET			ADMIN
Time-based Activate Relay nr(x) for (y) secs	RLYx:y		0..99 secs	ADMIN & USER

SMS message format is:

Password<space>***Command1***<space>***Command2***<space>***Command3***.....

Examples:

1111 ADDA:+901234567890 // Adds an Admin

1111 CALL:ON // Activates calls

5.1. Register (Add) Admin Number(s)

All admin numbers are authorized to make configurations, change & delete settings and reset device, add & remove numbers, and receive all alert notifications.

Note-1: If there is no Admin registered yet, any number who knows default password may add itself as Admin.

Note-2: After first Admin is registered to the device; only an existing Admin may add another Admin.

Note-3: Total 3 people can be added as Admin.

Authorization : Admins only (or first number on first use)

Format : ***Password***<space>***ADDA:Number***

Example : 1111 ADDA:+901234567890

Responses :

- Process Succeed.* // format & password is correct
- Process Failed!* // format is wrong
- Record Succeed. Memory Full* // record done but now memory is full
- Record Failed! Memory Full* // cannot record because memory is full

5.2. Change Password

Authorization	:	Admins only
Format	:	Password<space>PASS:NewPassword
Example	:	1111 PASS:6666
Responses	:	<i>Process Succeed.</i> // format & password is correct <i>Process Failed!</i> // format is wrong

Note: New Password must be always different than "1111".

5.3. Delete Admin

Authorization	:	Admins only
Format	:	Password<space>DELA:Number
Example	:	1111 DELA:+901234511111
Responses	:	<i>Process Succeed.</i> // format & pass is correct. Nr exists <i>Process Failed!</i> // format is wrong <i>Record Not Found! Process Failed</i> // nr does not exist

5.4. Alert Calls Activate / Deactivate

Alert Call feature is used if you need a Phone Call to warn you after you receive alert SMS.

These Calls do not include a voice record. It's a free-call to ring your phone for around 45 seconds. Alert Calls are DISABLED (OFF) as factory default.

Authorization	:	Admins only
Format	:	Password<space>CALL:ON Password<space>CALL:OFF
Examples	:	1111 CALL:ON // enables phone calls 1111 CALL:OFF // disables phone calls
Responses	:	<i>Process Succeed.</i> // format & pass is correct <i>Process Failed!</i> // format is wrong

5.5. Change SMS Text Message Contents

You can change Alarm SMS Text Message Contents according to your requirements. Thus, you will be able to rename Alarm words instead of remembering which input is connected to which equipment.

Note: Message Content is limited to 32 characters. Upper- or lower-case letters and digits are allowed to use. Only English letters are accepted according to ASCII.

Content index list is below:

PAT0	:	Keep Alive
PAT1...4	:	Input1...4 Low-to-High change alert
PAT9...12	:	Input1...4 High-to-Low change alert (i.e. Input1 matches with PAT9)
PAT17	:	Device Activated (or power restored)

Authorization : Admins only

Format : **Password<space>PATx:AlarmText#**

Examples : 1111 PAT1:Office Door Opened# // Input1 High alarm content changed
 1111 PAT9:Office Door Closed# // Input1 Low alarm content changed

Responses : *Process Succeed.* // format & pass is correct
Process Failed! // format is wrong

5.6. Set Heartbeat (Keep Alive) Interval Period

You may want to see device status automatically under some periods and make sure everything is working properly. Reporter's Heartbeat (or keep alive) feature makes this happen. As a factory default it is set to 0 hours (which means function is disabled). You may set this between 0...999 Hours (more than 40 days!).

Each keep alive message will include all inputs and outputs current status, mode selection, call activation, keep alive current interval setting and current GSM CSQ signal level.

Authorization : Admins only

Format : **Password<space>KA:Period**

Examples : 1111 KA:24 // Set keep alive for once per day
 1111 KA:0 // Disable keep alive messages

Responses : *Process Succeed.* // format & pass is correct
Process Failed! // format is wrong

5.7. Restore Factory Defaults (RESET)

Resetting the device does not mean any performance change on this device. Reset only deletes all registered numbers and deletes all configurations & password settings. Thus, device will restore itself into factory settings.

Authorization : Admins only

Format : **Password<space>RESET**

Examples : 1111 RESET // reset device

Responses : *Process Succeed.* // format & pass is correct
Process Failed! // format is wrong

6. CHECK DEVICE STATUS (STATUS QUERY)

While device is in Config mode, you may send a Status Query SMS to Reporter. It will reply to you with detailed current I/O status, some settings and GSM signal level information.

Authorization : Admins only

Format	:	<i>Password</i> <space> <i>STATUS</i>	
Examples	:	1111 STATUS	// ask status
Responses	:	<i>CALL:OFF</i>	// alert call feature is disabled
		<i>KA:24</i>	// keep alive period is 24 hours
		<i>SIGNAL:26</i>	// very good GSM signal (between 0..31)
		<i>Process Failed!</i>	// format is wrong

7. TROUBLESHOOTING

TROUBLE	REASON	SOLUTION
Network LED blinks fast, never blinks slowly	SIM card not inserted	Remove power adaptor. Insert SIM card first and then power device.
	PIN code not disabled	Remove power adaptor and then SIM card. Insert SIM card into a mobile phone. Disable SIM Card PIN protection from settings. Insert SIM card to your device first and then power device.
	Signal level not enough / No network	Change antenna / Change device location or try with another GSM operator until finding good signal level.
I don't receive replies to my SMS text messages	Device is at sleep mode	Press Config button and follow instructions above
	SIM card not activated or not enough credit (for prepaid cards)	Remove SIM and insert it in a mobile phone. Make sure SMS services are working properly
	Your mobile phone SMS services are working over internet	Disable "SMS Over Internet" feature from your mobile phone (I.e.: Disable iPhone iMessage / Xiaomi MiMessage)
Alarm occurred, I received SMS but I didn't receive a Call	Call feature not activated	Check Alert Calls Activate instructions
	SIM card Call service not activated	Contact SIM card provider
Alarm occurred, I received Call but didn't receive an SMS	Network signal was not enough on Reporter location or your own mobile phone's location.	Check signal level of Reporter. Sometimes SMS messages are delivered after some period of its sent, caused by GSM operators.
	Low credit on prepaid card	Check your credit (if prepaid cards used).

8. TECHNICAL SPECIFICATIONS

GX2140-DLBO – Technical Specifications	
Power Supply	<ul style="list-style-type: none"> • 2 x CR123A Lithium Batteries (NOT included)
Battery Life	<ul style="list-style-type: none"> • More than 1 year under normal usage
Inputs	<ul style="list-style-type: none"> • 4 x Volt-free inputs
GSM Module	<ul style="list-style-type: none"> • 2G Quad band 850/900/1800/1900 MHz
Antenna	<ul style="list-style-type: none"> • 2dBi Replaceable SMA type antenna
Event Notifications	<ul style="list-style-type: none"> • SMS / Call: Input Change Events • SMS / Call: Power Up • SMS for Keep Alive Messages • SMS for Status Query
Admin Capacity	<ul style="list-style-type: none"> • 3 Admins
Configurations via SMS	<ul style="list-style-type: none"> • Change password • Add & delete admins • Activate/deactivate alert Call function • Set keep alive internal • Change alert SMS contents • Reset device
Security	<ul style="list-style-type: none"> • CallerID & Password
Operating Temperature	<ul style="list-style-type: none"> • -10 °C ~ + 50 °C
Dimensions	<ul style="list-style-type: none"> • 115 x 90 x 55 mm
IP Water & Dust Protection	<ul style="list-style-type: none"> • IP67
Package Content	<ul style="list-style-type: none"> • 1 x GX2140-DLBO/H GSM Alarm & Controller Device • 1 x User Manual • 4 x Fixing Screws & Fixing Plugs

